

| REVISIONS |     |             |      |          |
|-----------|-----|-------------|------|----------|
| ZONE      | REV | DESCRIPTION | DATE | APPROVED |
|           |     |             |      |          |

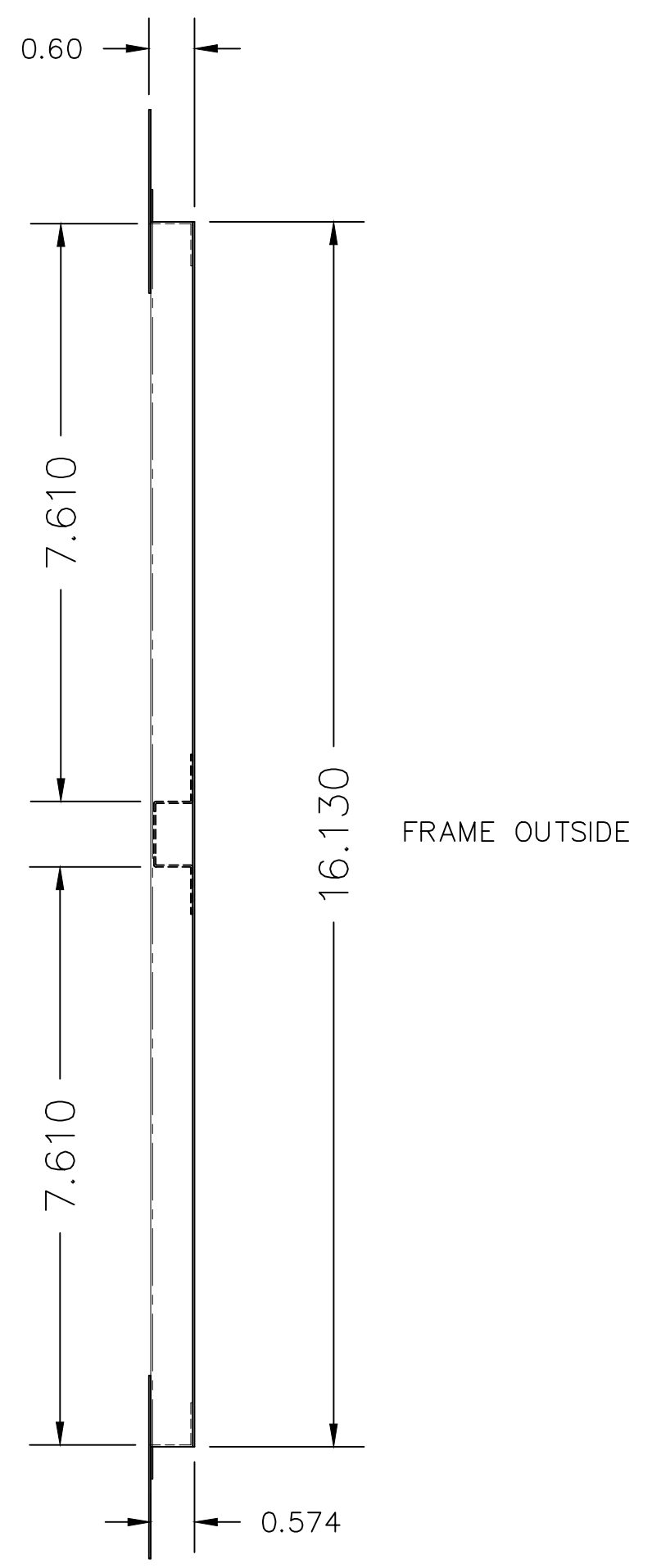
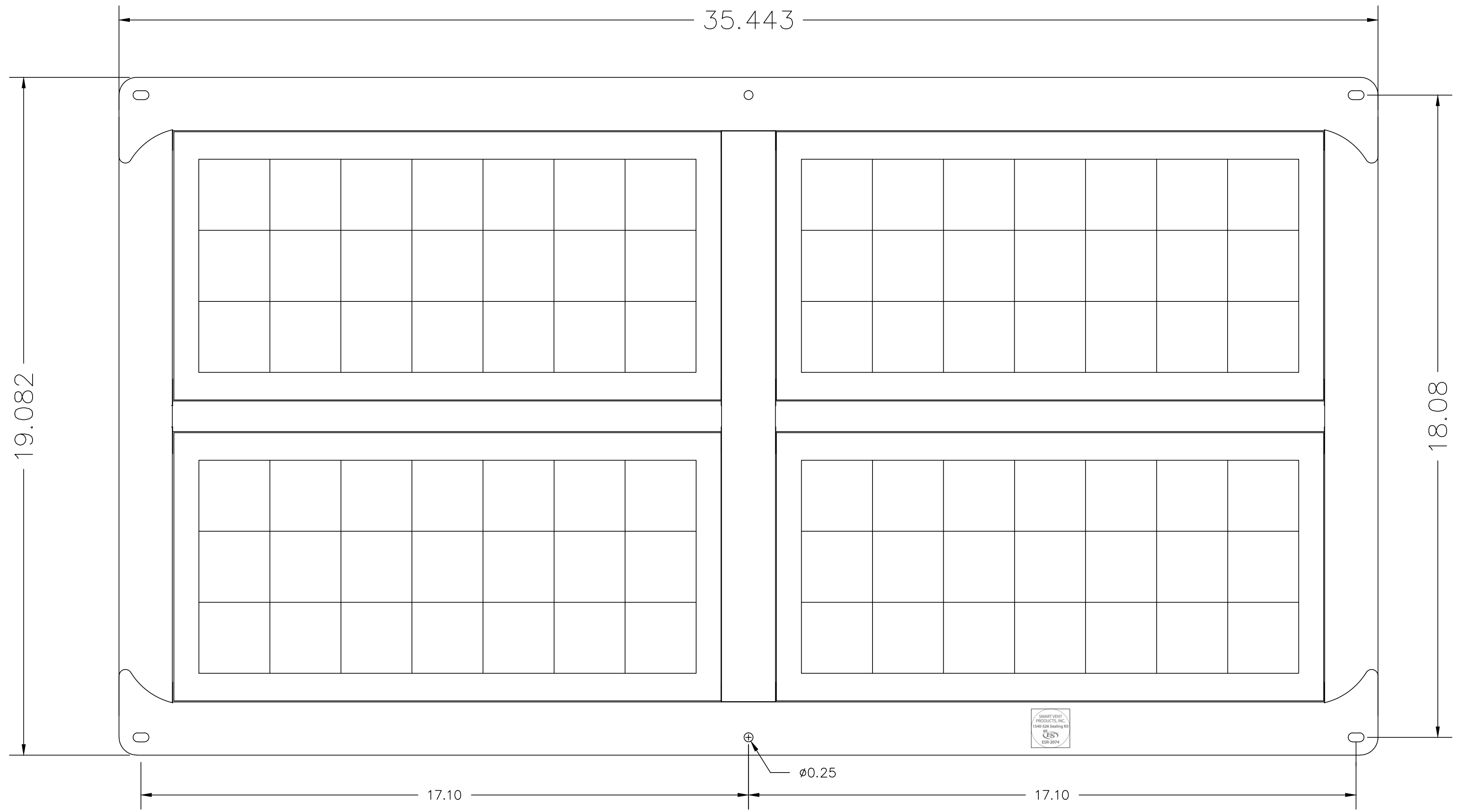
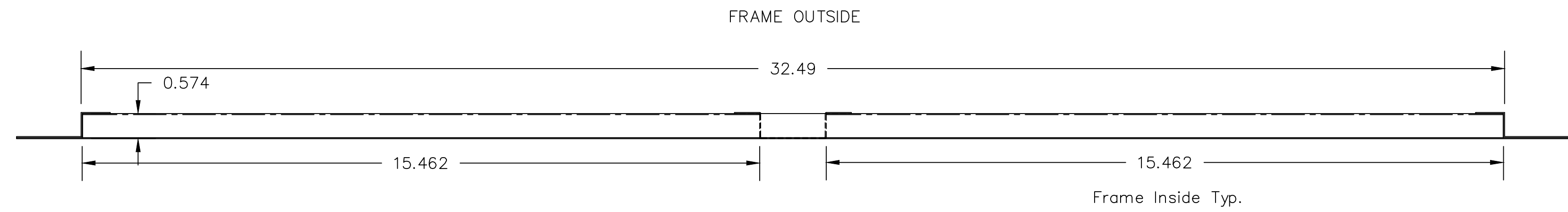

SEALING KIT #1540-526-4  
 For a rough opening 33.5" X 16.38"  
 POWDER COATED WHITE  
 304 STAINLESS STEEL

| ITEM | DESCRIPTION | QTY |
|------|-------------|-----|
|      |             |     |

TOLERANCES UNLESS OTHERWISE SPECIFIED  
 X.X +/-0.06  
 X.XX +/-0.03  
 X.XXX +/-0.005

**877-441-8368**  
**SMARTVENT.COM**

THE INFORMATION CONTAINED IN THIS DRAWING IS THE SOLE PROPERTY OF SMART VENT INC. ANY REPRODUCTION OR USE OF THIS INFORMATION WITHOUT THE WRITTEN PERMISSION OF SARGENT METAL FABRICATORS IS PROHIBITED.

**SMART VENT PRODUCTS, INC**  
**430 Andbro Dr. Unit 1**  
**Pitman NJ 08071**

2x2 Multi-Frame Sealing Kit  
 (contractor)

|        |          |              |       |
|--------|----------|--------------|-------|
| SIZE   | FSCM NO. | DWG NO.      | REV   |
| DR. BB |          | 1540-526-4   |       |
|        |          | DATE: 5/4/20 | SHEET |